

Dynamic simulation of the composting process - the sCOMPOS model



D.S.F. Neves^{a,*}, A.P.D. Gomes^a, L.A.C. Tarelho^a, M.A.A. Matos^a

^a Department of Environment and Planning
University of Aveiro
Campus Universitário de Santiago
3810-193 Aveiro (Portugal)

* Corresponding author : dneves@ua.pt
Tel: (+351) 234 370 349
Fax: (+351) 234 429 290

Results

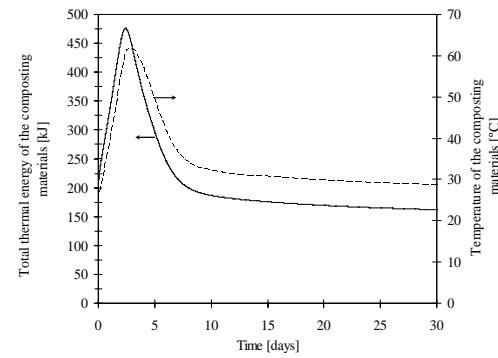
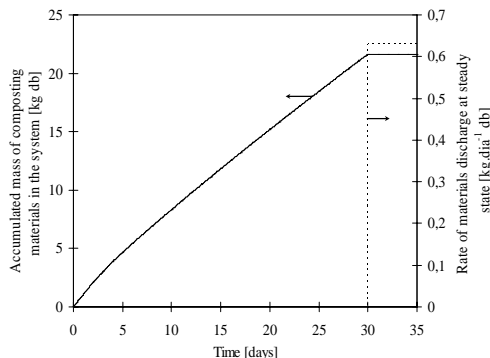
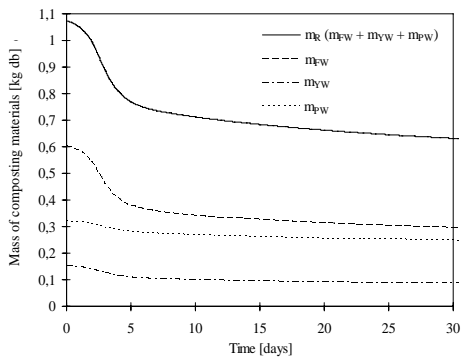

sCOMPOS model

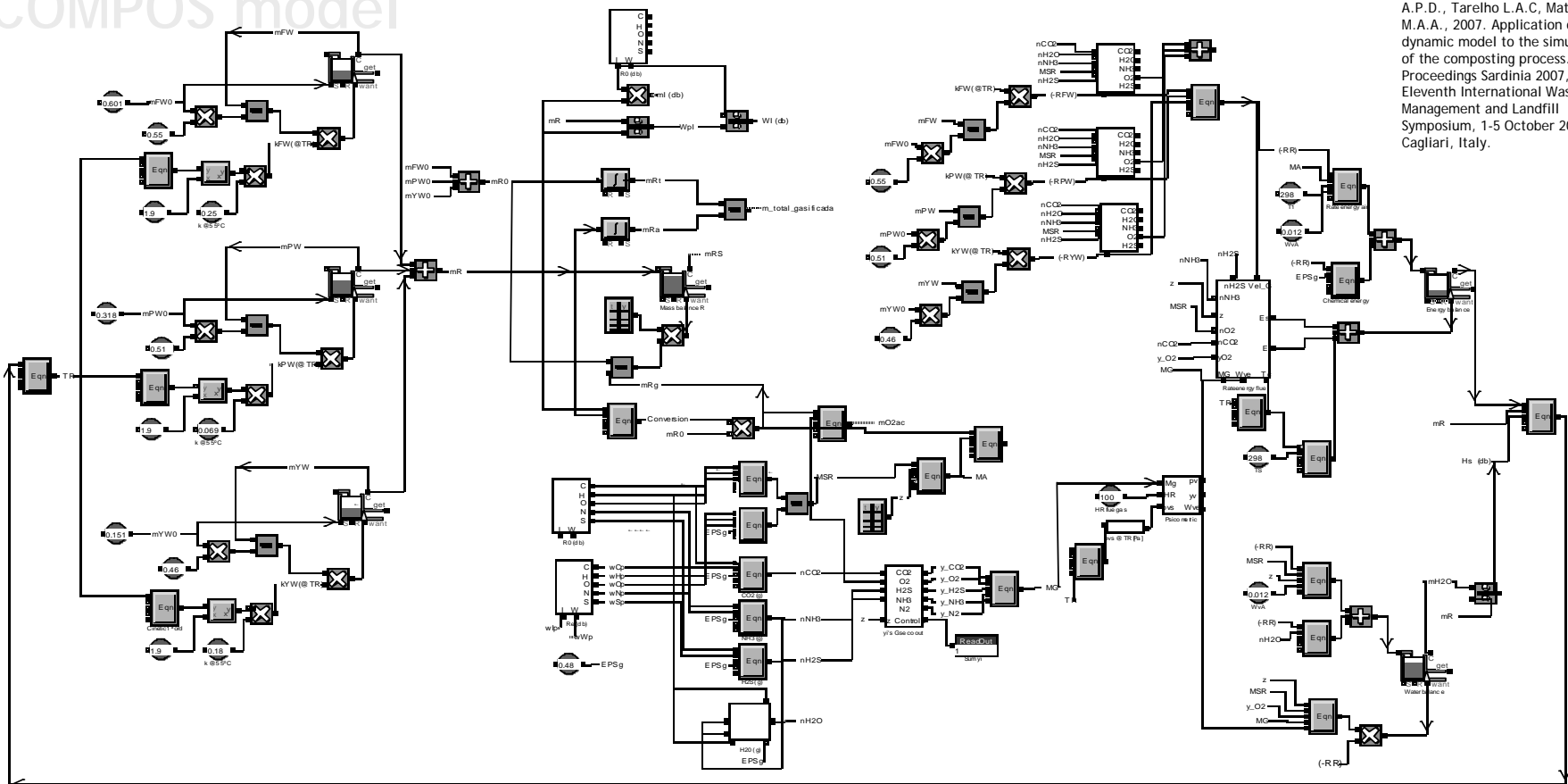

Source: Neves D.S.F., Gomes, A.P.D., Tarelho L.A.C., Matos M.A.A., 2007. Application of a dynamic model to the simulation of the composting process. Proceedings Sardinia 2007, Eleventh International Waste Management and Landfill Symposium, 1-5 October 2007, Cagliari, Italy.